

Spiral-Spectral Fluid Simulation

Qiaodong Cui Timothy Langlois Pradeep Sen Theodore Kim
Yale University Adobe Research University of California, Santa Barbara Yale University

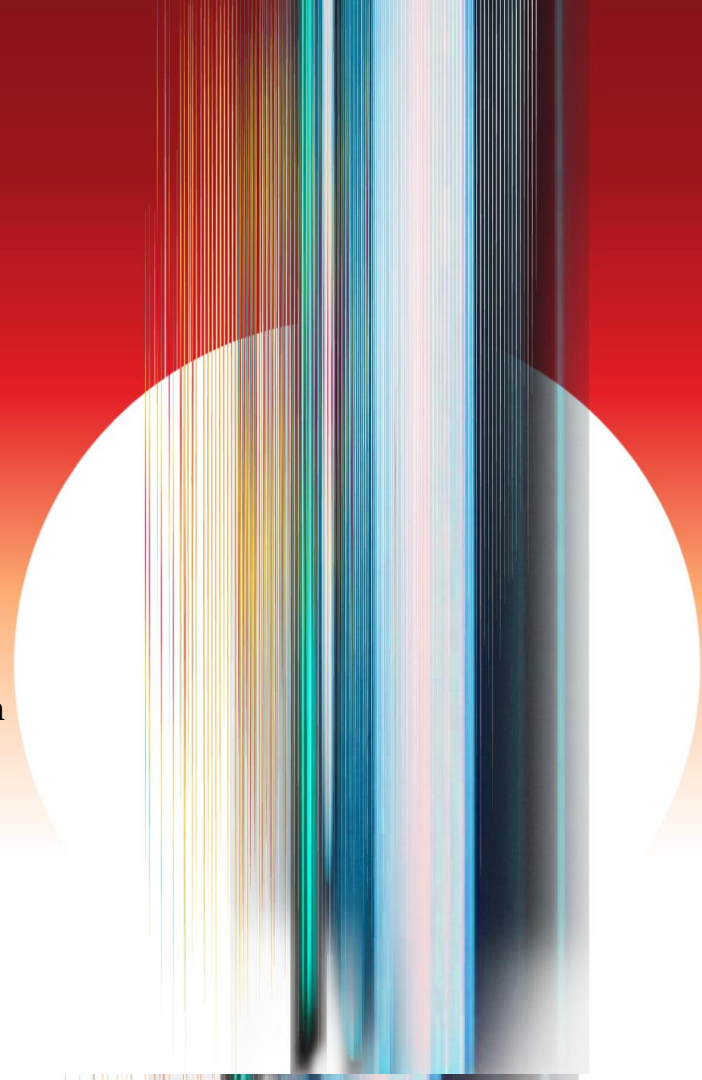

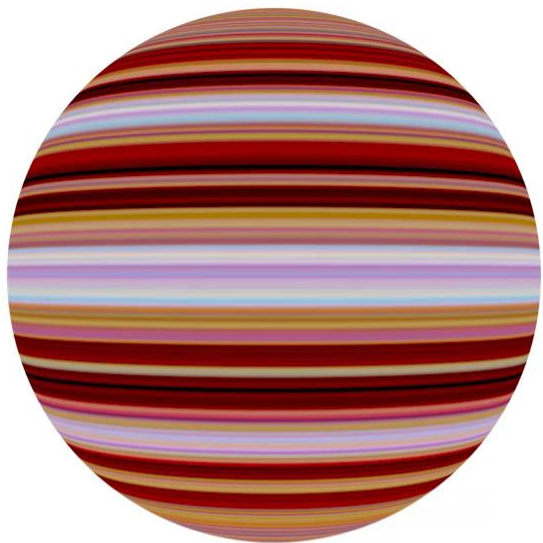

Spheres

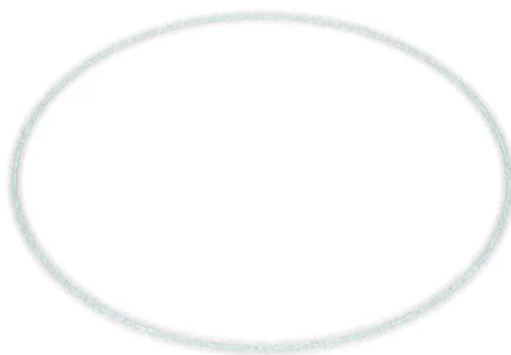
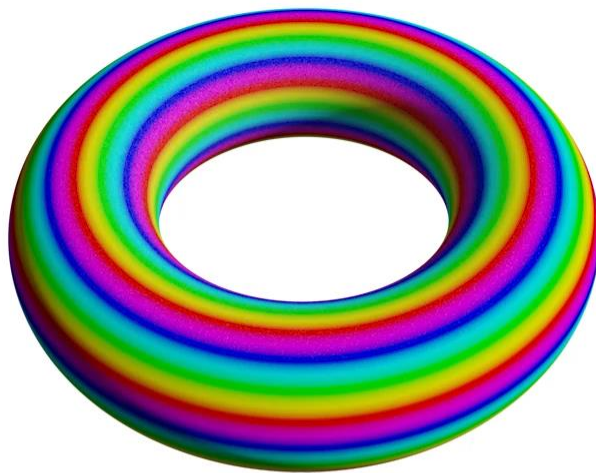

Tori

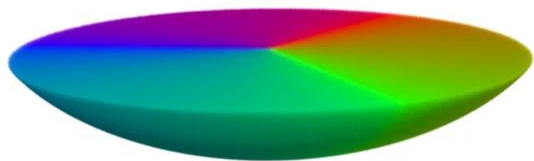

Spheroids

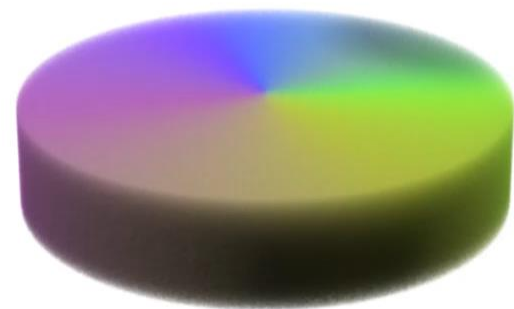

Cylinders

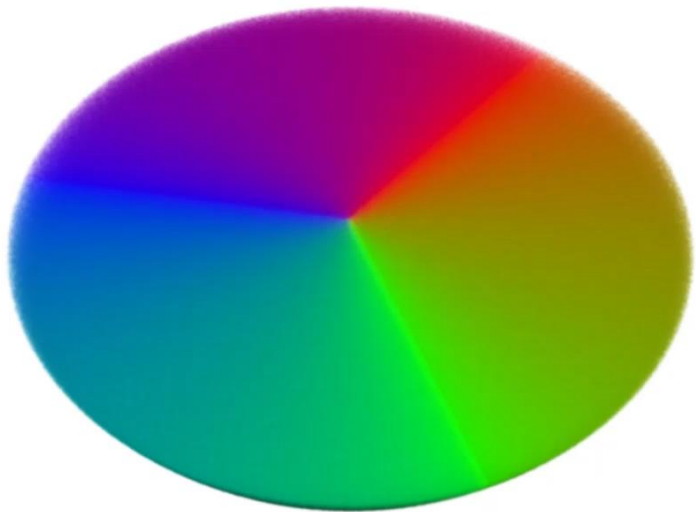

Volumetric sphere

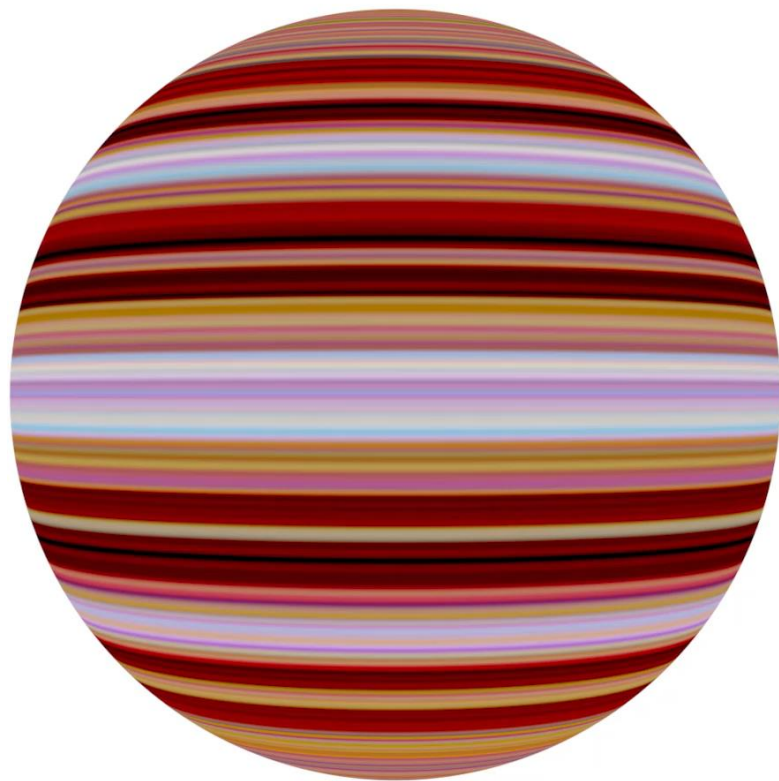

Codimensional sphere

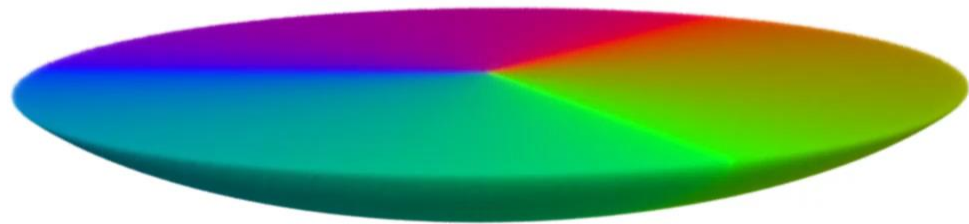
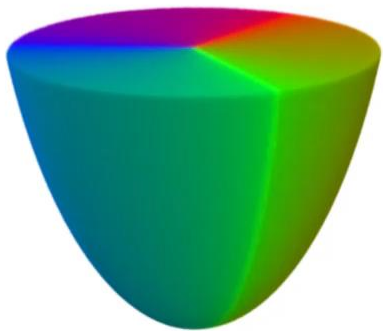

Spheroids ($b=0.4$), 6K basis functions

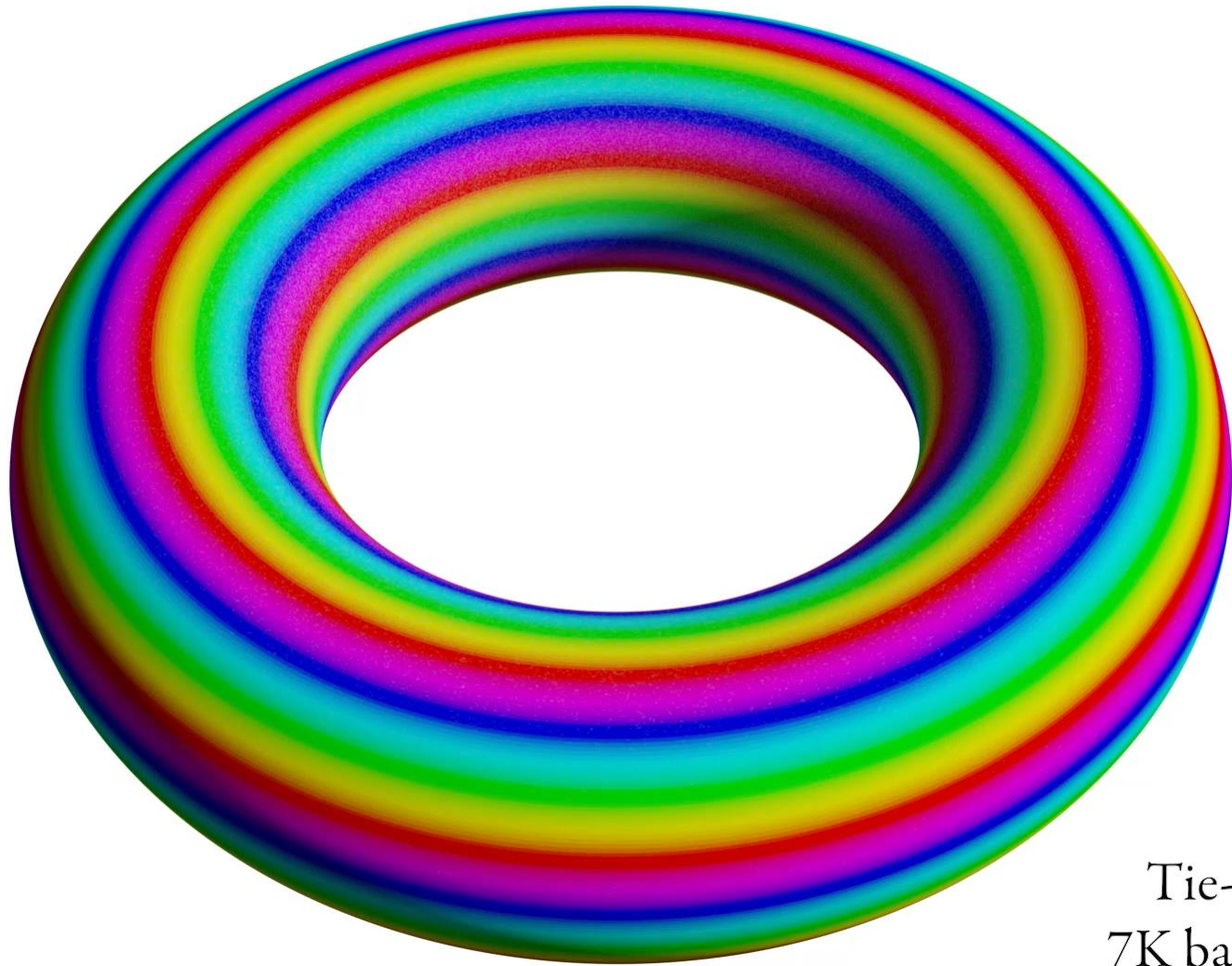

Tie-Dye Torus
7K basis functions

Outline

- Previous work
- Scalable Laplacian Eigenfluids
- Our methods
- Results
- Contributions and future work

Simulations in Spherical Coordinates

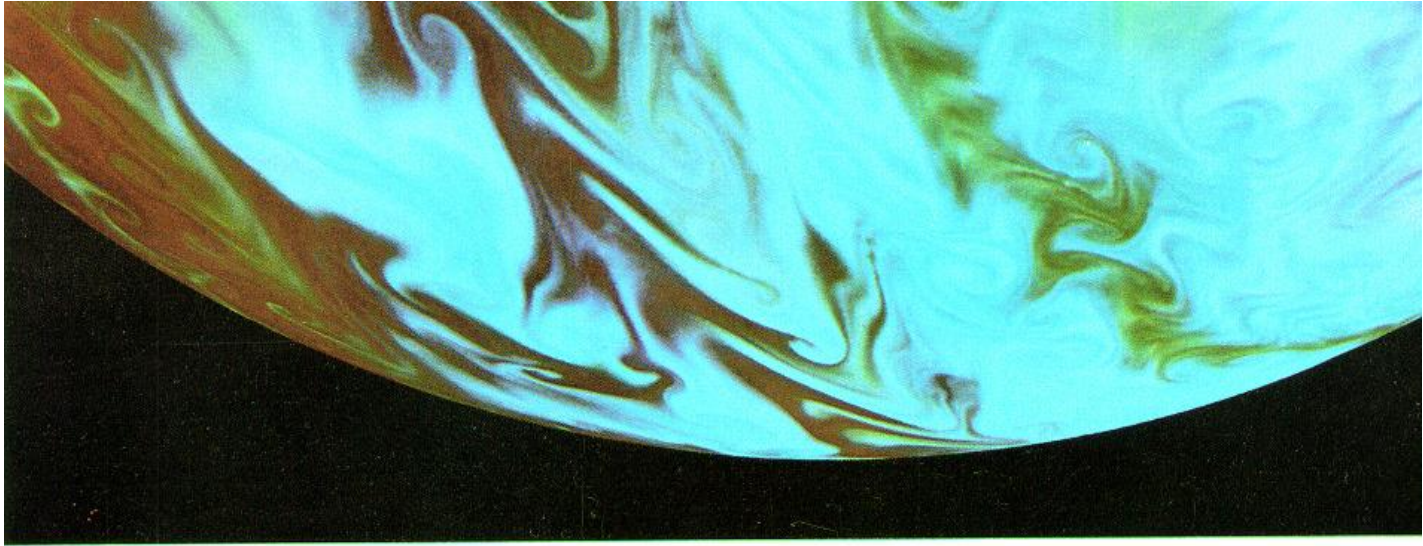

Planetary Flow: [Yaeger et al. 1986]

Simulations in Spherical Coordinates

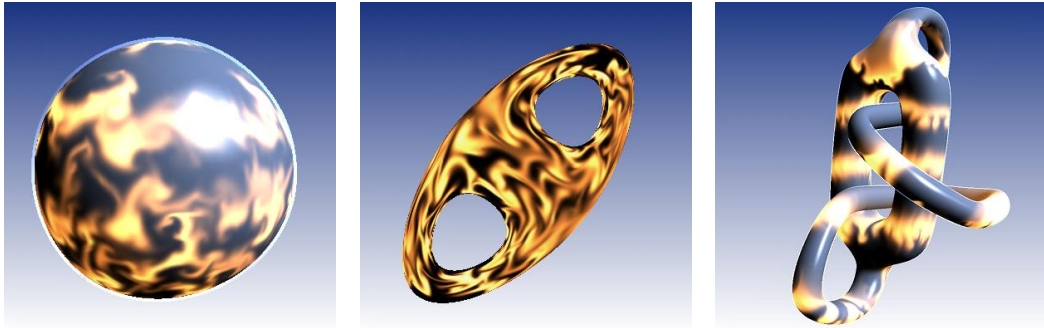

Curvilinear Coordinates: [Stam 2003]

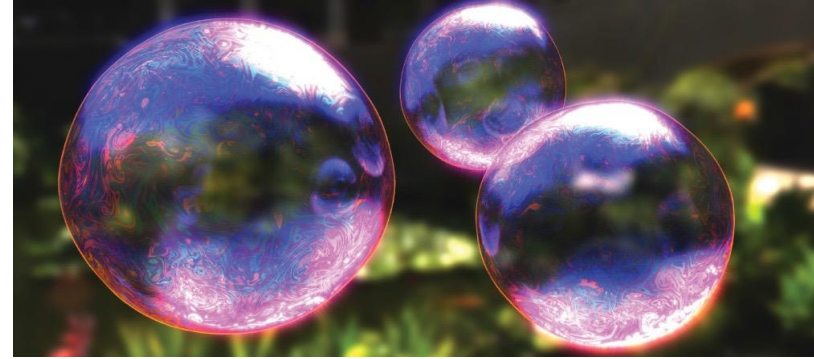

Spherical Coordinates: [Hill et al. 2016]

Scalable Laplacian Eigenfluids

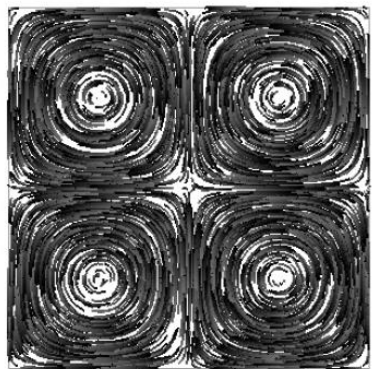

[De Witt et al. 2012]

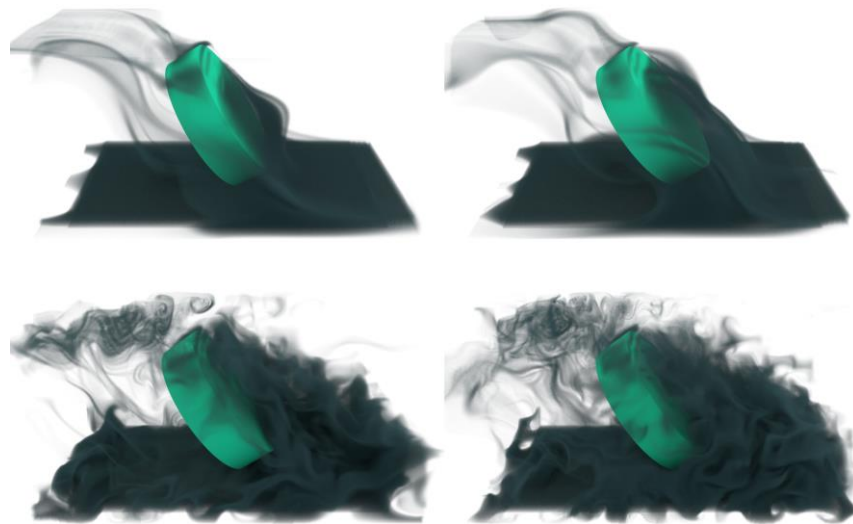
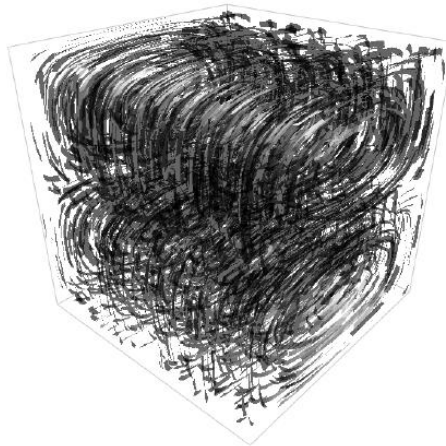

[Cui et al. 2018]

Outline

- Previous work
- Scalable Laplacian Eigenfluids
- Our methods
- Results
- Contributions and future work

Laplacian Eigenfluids

$$\dot{\mathbf{u}} = -\mathbf{u} \cdot \nabla \mathbf{u} + \nu \nabla^2 \mathbf{u} - \nabla p + \mathbf{f}$$

$$\nabla \cdot \mathbf{u} = 0$$

$$\mathbf{u} = \sum_{i=1}^r w_i \Phi_i + w_1 \Phi_1 + w_2 \Phi_2 + w_3 \Phi_3 + \cdots + w_s \Phi_s$$

$$\nabla \cdot \Phi_i = 0$$

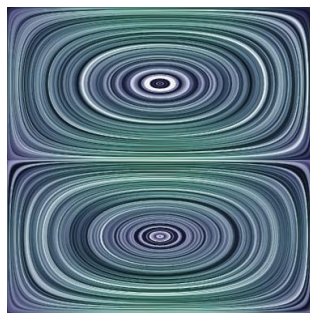
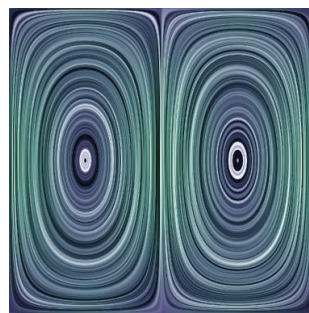
 Φ_1  Φ_2  Φ_3

...

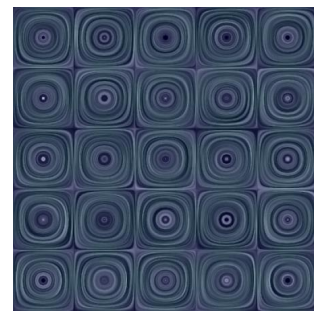
 Φ_s

Reconstruction Bottleneck

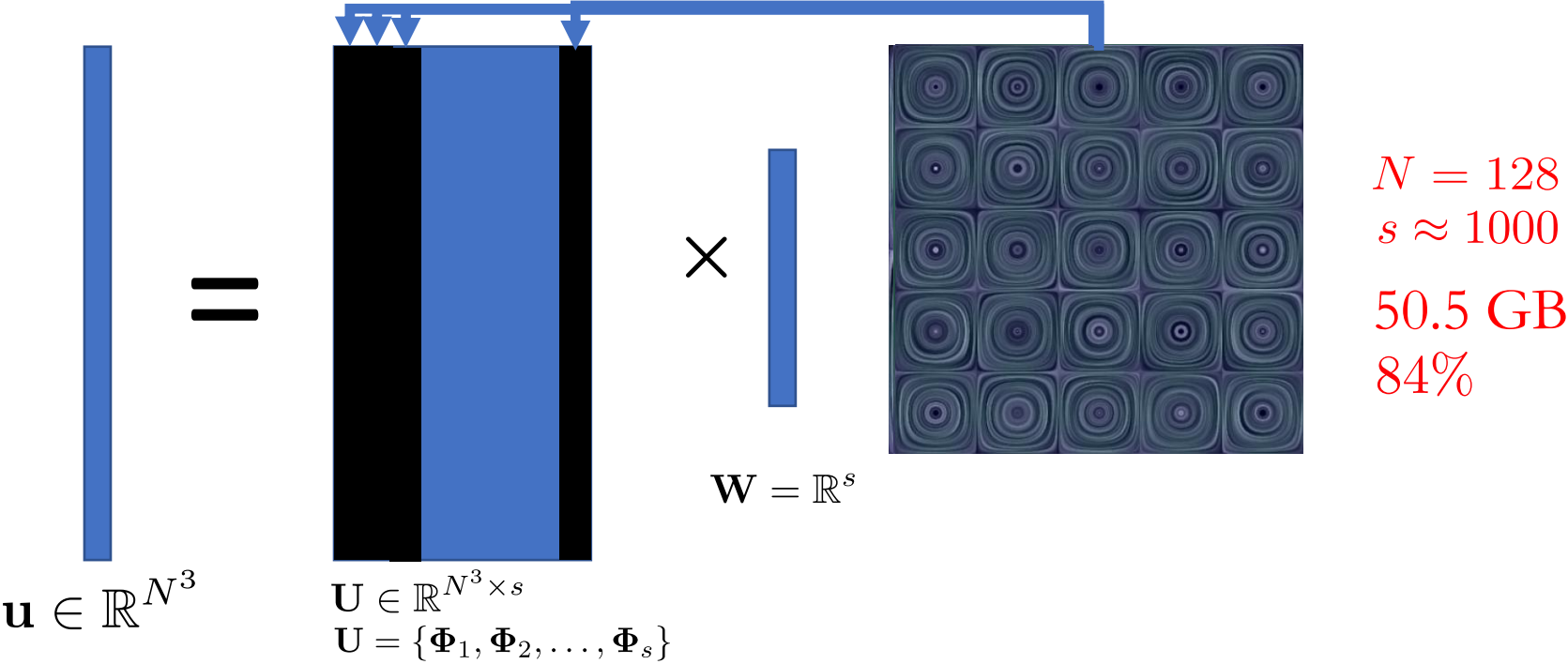

Scalable Laplacian Eigenfluids

- Analytical basis admits fast transformations

$$\Phi_x = -i_2 \sin(i_1 x) \cos(i_2 y)$$

$$\Phi_y = i_1 \cos(i_1 x) \sin(i_2 y)$$

- Memory complexity: $O(sN^3) \longrightarrow O(s)$

- Time complexity: $O(sN^3) \longrightarrow O(N^3 \log(N))$

- Limited to rectangular domains (Cartesian coordinates)

Cartesian Versus Polar

$$\Phi_x = -i_2 \sin(i_1 x) \cos(i_2 y)$$

$$\Phi_y = i_1 \cos(i_1 x) \sin(i_2 y)$$

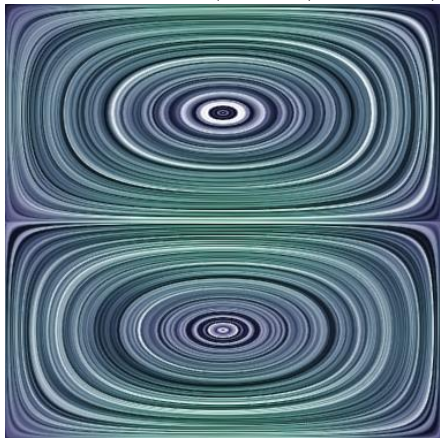

$$\nabla \cdot \Phi = \frac{\partial \Phi_x}{\partial x} + \frac{\partial \Phi_y}{\partial y} = 0$$

$$\Phi_r = ?$$

$$\Phi_\theta = ?$$

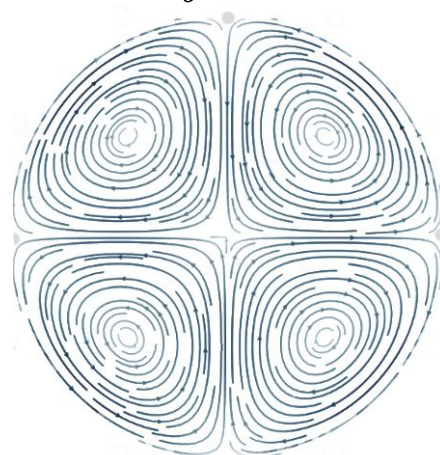

$$\nabla \cdot \Phi = \Phi_r + r \frac{\partial \Phi_r}{\partial r} + \frac{\partial \Phi_\theta}{\partial \theta} = 0$$

Outline

- Previous work
- Scalable Laplacian Eigenfluids
- **Our methods**
- Results
- Contributions and future work

Polar Coordinates

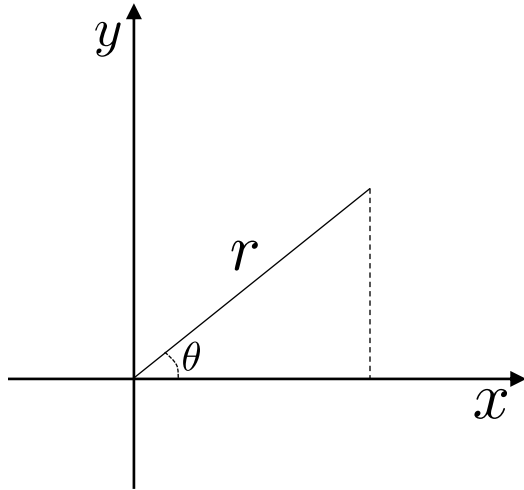

$$x = r \cos(\theta)$$

$$y = r \sin(\theta)$$

$$\nabla \cdot \mathbf{u} = \frac{1}{r} \left(\mathbf{u}_r + r \frac{\partial \mathbf{u}_r}{\partial r} + \frac{\partial \mathbf{u}_\theta}{\partial \theta} \right)$$

Principles for Good Bases

- Support FFT-based transformations
 - Fast reconstruction & no basis storage
- Separable along each coordinate directions
- Smooth and continuous
- Complete

Eigenfluids in Polar Coordinates

$$\nabla \cdot \mathbf{u} = \left(\mathbf{u}_r + r \frac{\partial \mathbf{u}_r}{\partial r} + \frac{\partial \mathbf{u}_\theta}{\partial \theta} \right) = 0$$

$$\mathbf{u}_r = A(r)B(\theta)$$

$$\mathbf{u}_\theta = C(r)D(\theta)$$

$$A(r) \boxed{B(\theta)} + r \frac{dA(r)}{dr} \boxed{B(\theta)} + C(r) \boxed{\frac{dD(\theta)}{d\theta}} = 0$$

$$B(\theta) = \frac{dD(\theta)}{d\theta}$$

Eigenfluids in Polar Coordinates

$$\mathbf{u}_r = A(r) \sin(i_2 \theta)$$

$$\mathbf{u}_\theta = C(r) \cos(i_2 \theta)$$

$$A(r) + r \frac{dA(r)}{dr} + C(r) = 0$$

$$A(r) = \sin(i_1 \pi r)$$

The First Basis Function

$$\begin{cases} \Phi_r^0(r, \theta) &= \sin(i_1 \pi r) \sin(i_2 \theta) \\ \Phi_\theta^0(r, \theta) &= \frac{1}{i_2} (\sin(i_1 \pi r) + i_1 \pi r \cos(i_1 \pi r)) \cos(i_2 \theta) \end{cases}$$

$$i_1, i_2 \in \mathbb{Z}^+$$

$$r \in [0, 1], \theta \in [0, 2\pi]$$

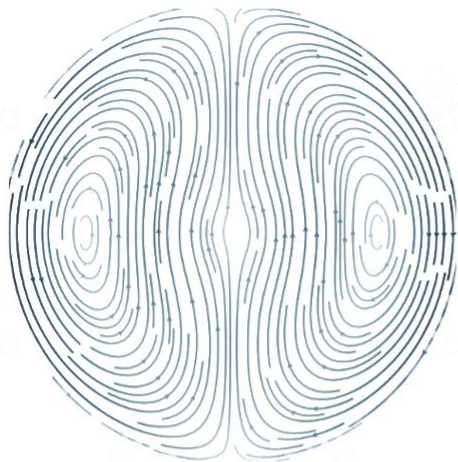

$$i_1 = 1, i_2 = 1$$

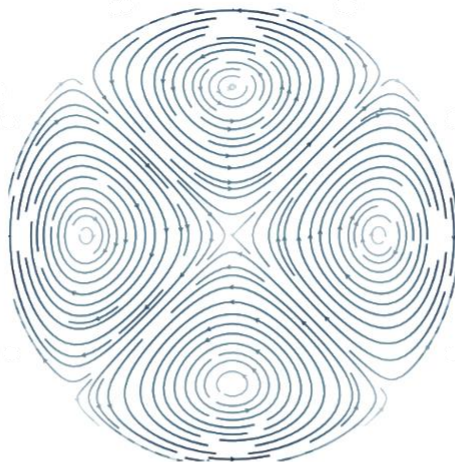

$$i_1 = 1, i_2 = 2$$



$$i_1 = 1, i_2 = 3$$

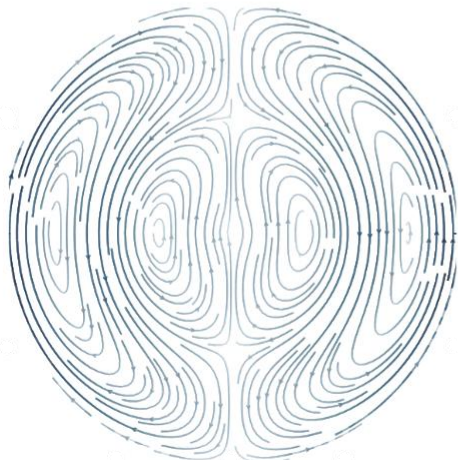

$$i_1 = 2, i_2 = 1$$

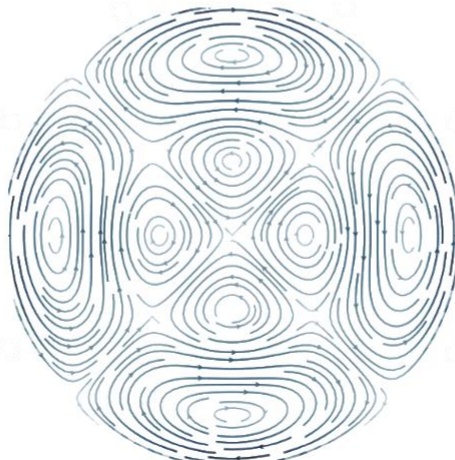

$$i_1 = 2, i_2 = 2$$

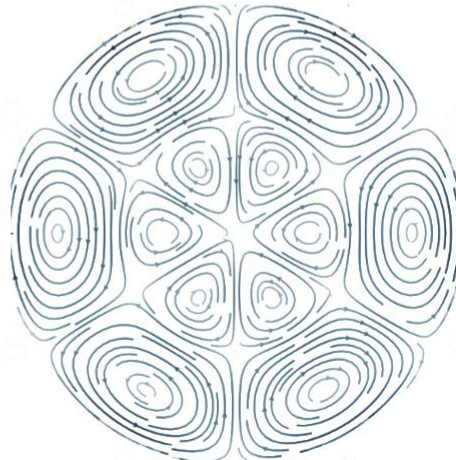

$$i_1 = 2, i_2 = 3$$

The Second Basis Function

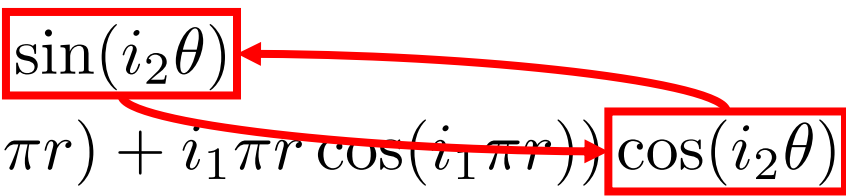
$$\begin{cases} \Phi_r^0(r, \theta) &= \sin(i_1 \pi r) \sin(i_2 \theta) \\ \Phi_\theta^0(r, \theta) &= \frac{1}{i_2} (\sin(i_1 \pi r) + i_1 \pi r \cos(i_1 \pi r)) \cos(i_2 \theta) \\ \Phi_r^1(r, \theta) &= \sin(i_1 \pi r) \cos(i_2 \theta) \\ \Phi_\theta^1(r, \theta) &= -\frac{1}{i_2} (\sin(i_1 \pi r) + i_1 \pi r \cos(i_1 \pi r)) \sin(i_2 \theta) \end{cases}$$

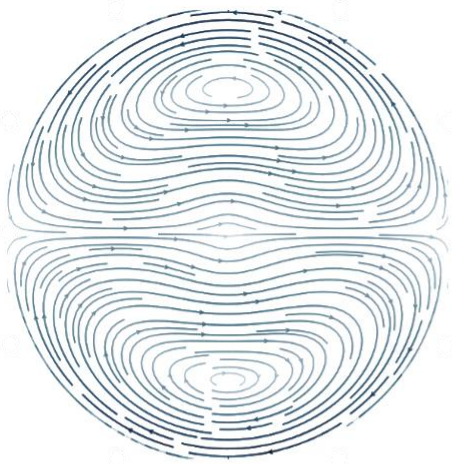

$i_1 = 1, i_2 = 1$

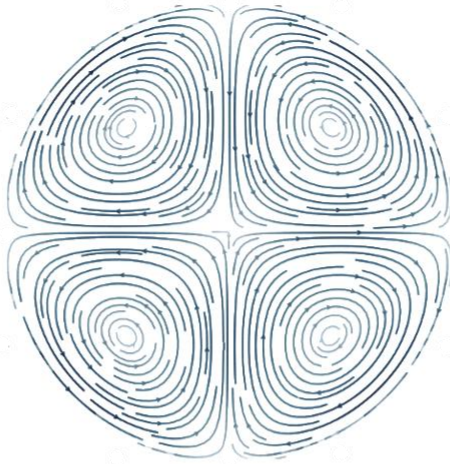

$i_1 = 1, i_2 = 2$

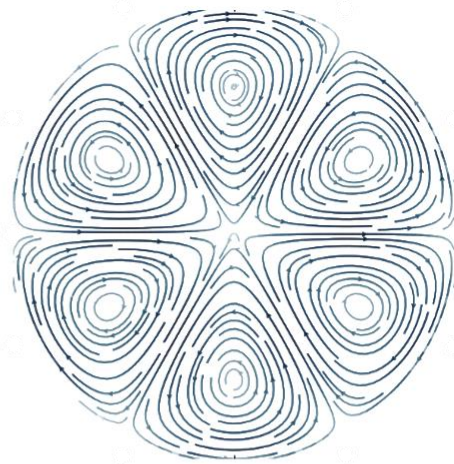

$i_1 = 1, i_2 = 3$

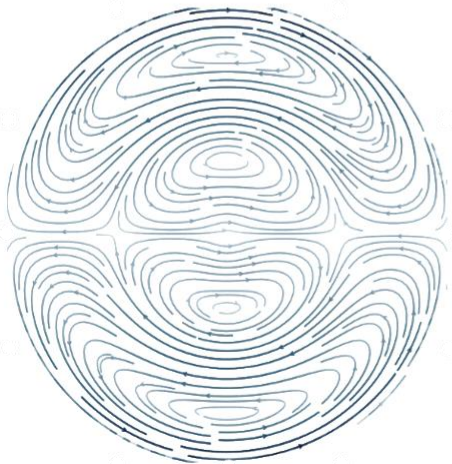

$i_1 = 2, i_2 = 1$

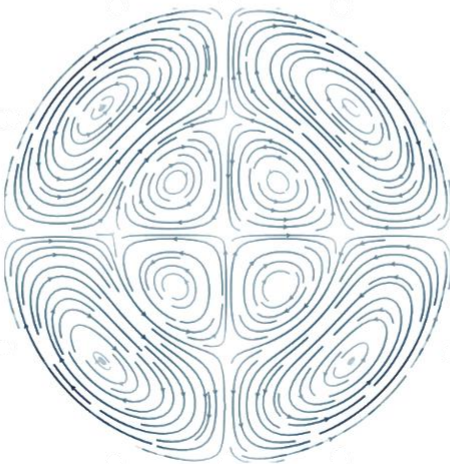

$i_1 = 2, i_2 = 2$

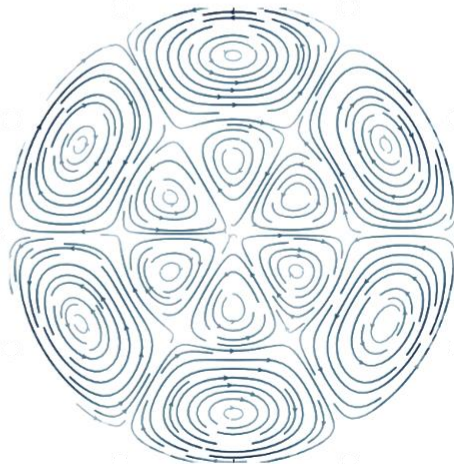

$i_1 = 2, i_2 = 3$

Reference result

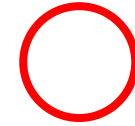

Result with Φ^0 and Φ^1

Problems at the Pole

$$\begin{cases} \Phi_r^0(0, \theta) = 0 \\ \Phi_\theta^0(0, \theta) = 0 \end{cases}$$

$$\begin{cases} \Phi_r^1(0, \theta) = 0 \\ \Phi_\theta^1(0, \theta) = 0 \end{cases}$$

Enrichment Basis Functions

$$A(r) + r \frac{dA(r)}{dr} + C(r) = 0$$

$$A = \cos(i_1 \pi r), \quad \cos(0) = 1$$

$$\begin{cases} \Phi_r^2 &= \cos(i_1 \pi r) \sin(i_2 \theta) \\ \Phi_\theta^2 &= \frac{1}{i_2} (\cos(i_1 \pi r) - i_1 \pi r \sin(i_1 \pi r)) \cos(i_2 \theta) \end{cases}$$

$$\begin{cases} \Phi_r^2(r=0) &= \sin(i_2 \theta) \\ \Phi_\theta^2(r=0) &= \frac{1}{i_2} \cos(i_2 \theta) \end{cases}$$

Boundary Condition at the Pole

$$\frac{\partial \mathbf{u}_r}{\partial \theta} = \mathbf{u}_\theta, \quad \frac{\partial \mathbf{u}_\theta}{\partial \theta} = -\mathbf{u}_r, \quad r = 0$$

$$\begin{cases} \Phi_r^2(r = 0) &= \sin(i_2 \theta) \\ \Phi_\theta^2(r = 0) &= \frac{1}{i_2} \cos(i_2 \theta) \end{cases}$$

$$i_2 = 1$$

Enrichment Basis Functions

$$\begin{cases} \Phi_r^2 &= \cos(i_1 \pi r) \sin(\theta) \\ \Phi_\theta^2 &= (\cos(i_1 \pi r) - i_1 \pi r \sin(i_1 \pi r)) \cos(\theta) \end{cases}$$

$$\begin{cases} \Phi_r^3 &= \cos(i_1 \pi r) \cos(\theta) \\ \Phi_\theta^3 &= (-\cos(i_1 \pi r) + i_1 \pi r \sin(i_1 \pi r)) \sin(\theta) \end{cases}$$

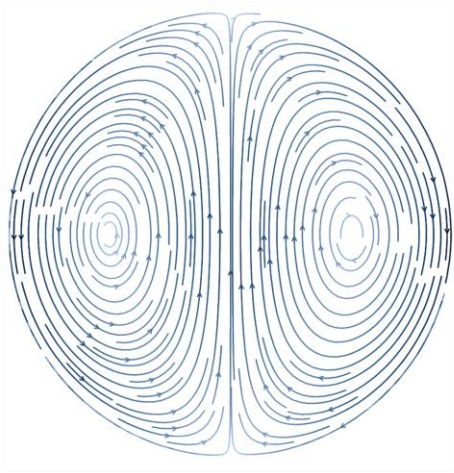

$$i_1 = 1/2$$

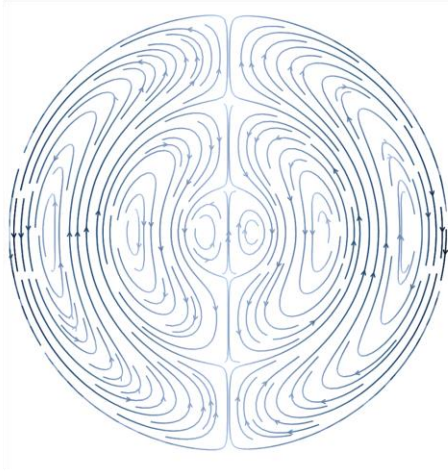

$$i_1 = 3/2$$

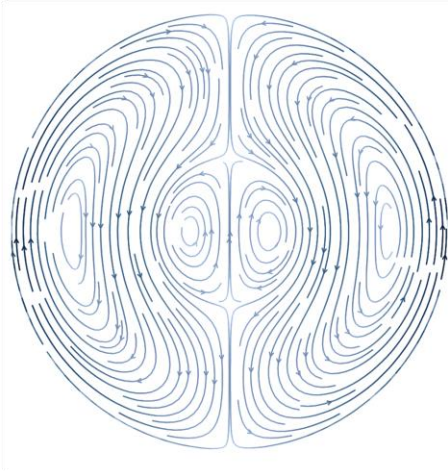

$$i_1 = 5/2$$

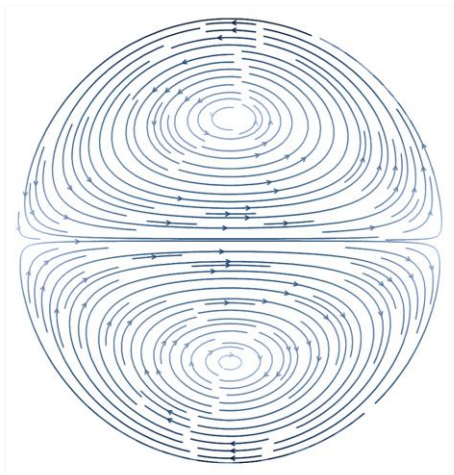

$$i_1 = 1/2$$

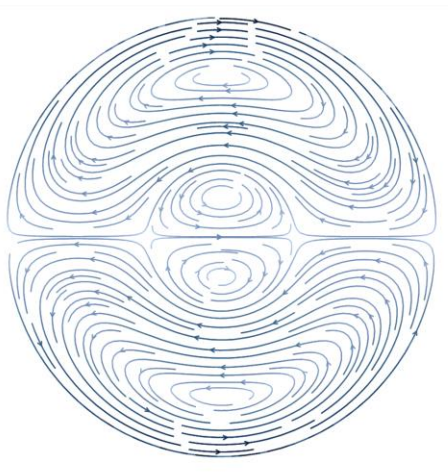

$$i_1 = 3/2$$

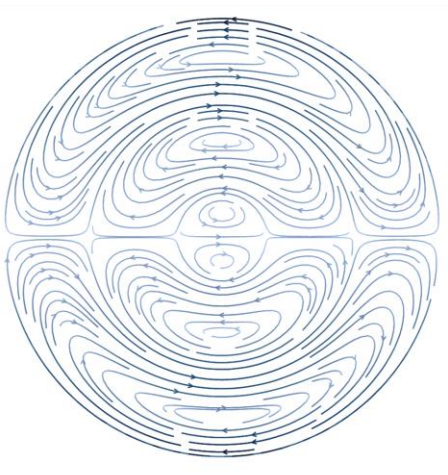

$$i_1 = 5/2$$

Without enrichment functions

With enrichment functions

Enrichment Basis Functions

$$\begin{cases} \Phi_r^4 & = 0, \\ \Phi_\theta^4 & = \sin(i_1 \pi r) \end{cases}$$

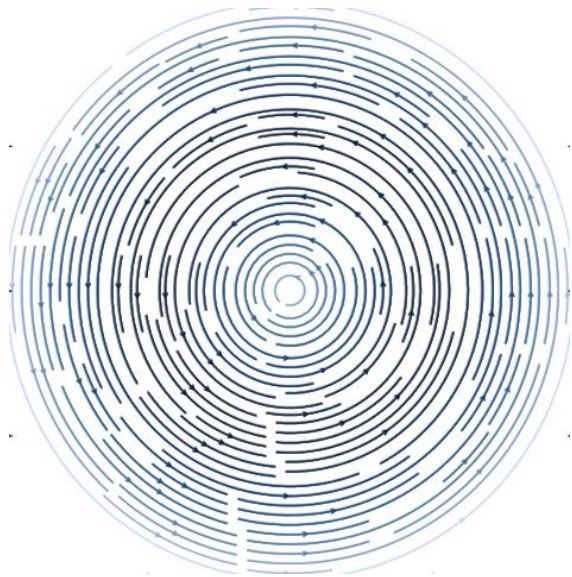

$$i_1 = 1$$

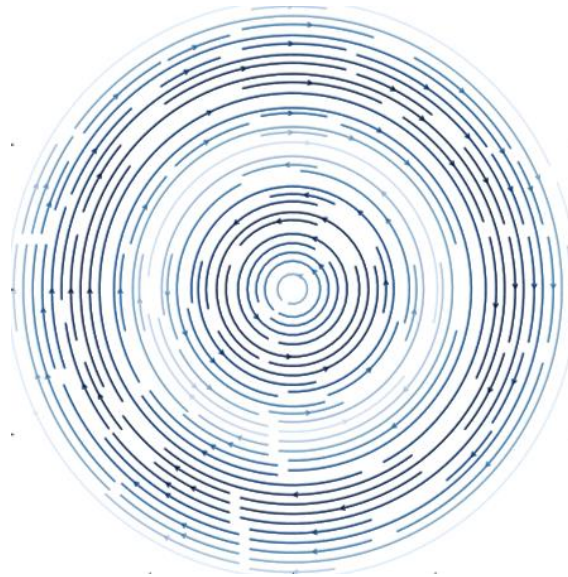

$$i_1 = 2$$

Basis Functions

Φ^0, Φ^1

Principal functions

Φ^2, Φ^3, Φ^4

Enrichment functions

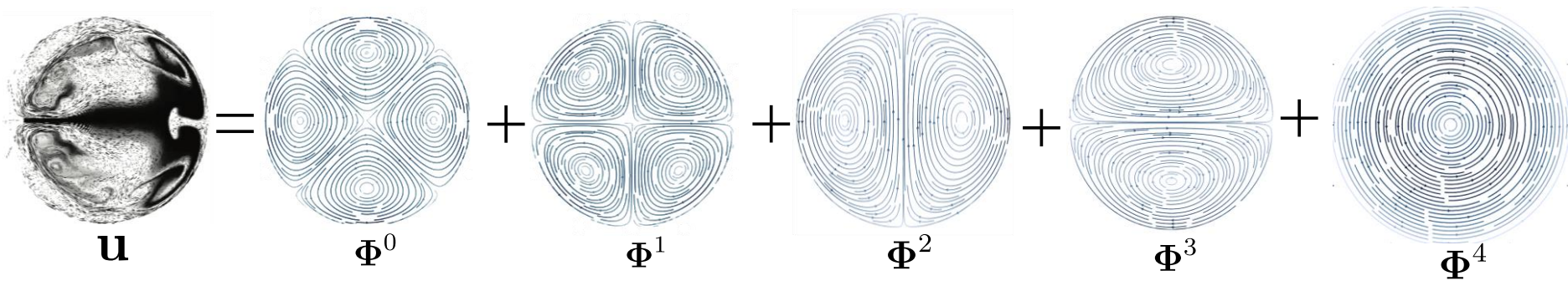

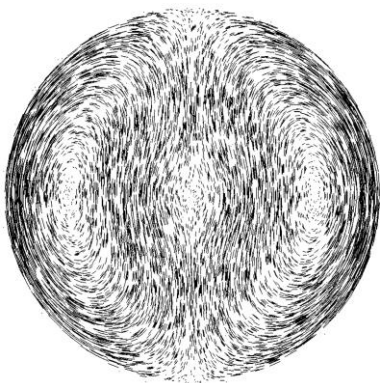

Φ^0

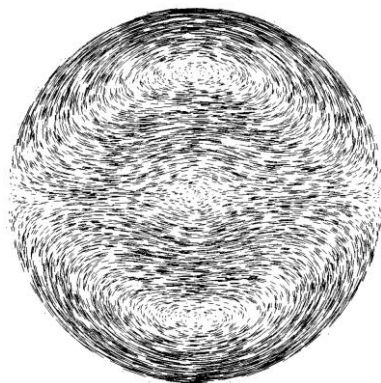

Φ^1

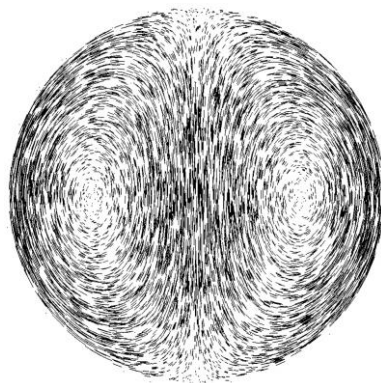

Φ^2

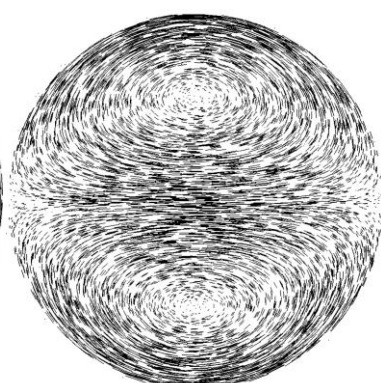

Φ^3

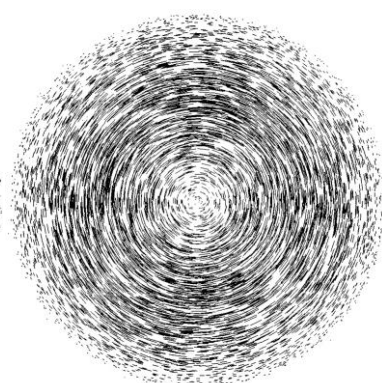

Φ^4

Fast Transformations

$$\begin{cases} \Phi_r^0(r, \theta) &= \sin(i_1 \pi r) \sin(i_2 \theta) \\ \Phi_\theta^0(r, \theta) &= \frac{1}{i_2} (\sin(i_1 \pi r) + i_1 \pi r \cos(i_1 \pi r)) \cos(i_2 \theta) \end{cases}$$

$$\mathbf{u}_r = \sum_{i=1}^r w_i \sin(i_1 \pi r) \cos(i_2 \theta)$$

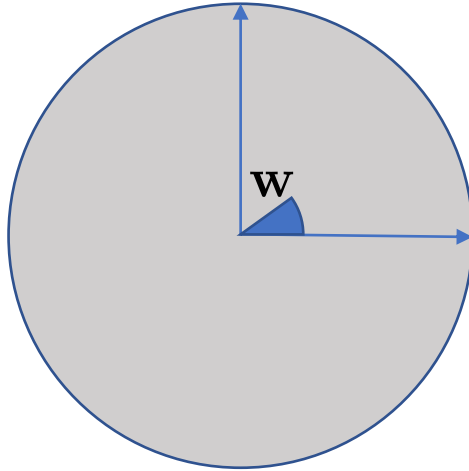

Fast Transformations

$$\begin{cases} \Phi_r^0(r, \theta) &= \sin(i_1 \pi r) \sin(i_2 \theta) \\ \Phi_\theta^0(r, \theta) &= \frac{1}{i_2} (\sin(i_1 \pi r) + i_1 \pi r \cos(i_1 \pi r)) \cos(i_2 \theta) \end{cases}$$

$$\mathbf{u}_r = \sum_{i=1}^r w_i \sin(i_1 \pi r) \cos(i_2 \theta)$$

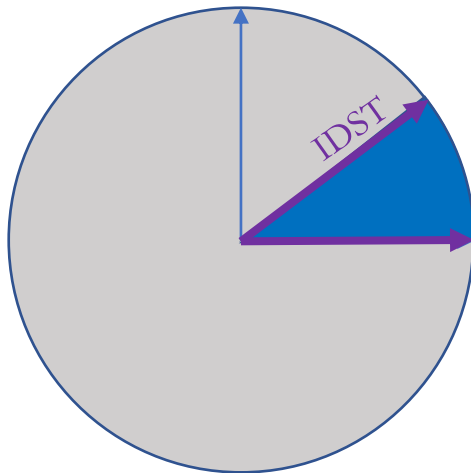

Fast Transformations

$$\begin{cases} \Phi_r^0(r, \theta) &= \sin(i_1 \pi r) \sin(i_2 \theta) \\ \Phi_\theta^0(r, \theta) &= \frac{1}{i_2} (\sin(i_1 \pi r) + i_1 \pi r \cos(i_1 \pi r)) \cos(i_2 \theta) \end{cases}$$

$$\mathbf{u}_r = \sum_{i=1}^r w_i \sin(i_1 \pi r) \cos(i_2 \theta)$$

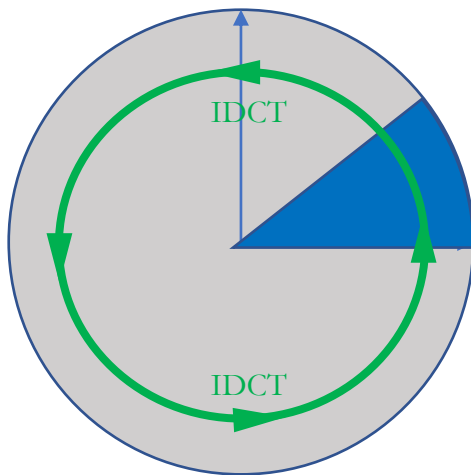

Fast Transformations

$$\begin{cases} \Phi_r^0(r, \theta) &= \sin(i_1 \pi r) \sin(i_2 \theta) \\ \Phi_\theta^0(r, \theta) &= \frac{1}{i_2} (\sin(i_1 \pi r) + i_1 \pi r \cos(i_1 \pi r)) \cos(i_2 \theta) \end{cases}$$

$$\mathbf{u}_r = \sum_{i=1}^r w_i \sin(i_1 \pi r) \cos(i_2 \theta)$$

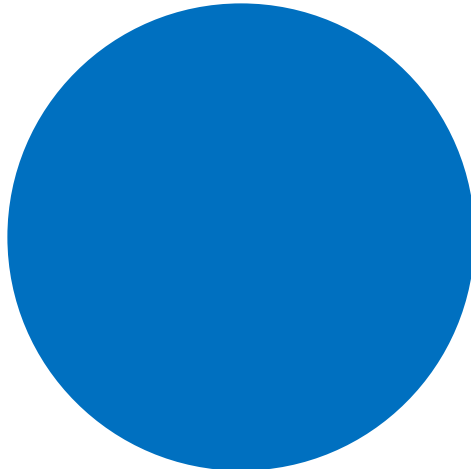

\mathbf{u}_r

Fast Transformations

$$\begin{cases} \Phi_r^0(r, \theta) &= \sin(i_1 \pi r) \sin(i_2 \theta) \\ \Phi_\theta^0(r, \theta) &= \frac{1}{i_2} (\sin(i_1 \pi r) + i_1 \pi r \cos(i_1 \pi r)) \cos(i_2 \theta) \end{cases}$$

$$\mathbf{u}_\theta = \sum_{i=1}^r \frac{w_i}{i_2} (\sin(i_1 \pi r) + i_1 \pi r \cos(i_1 \pi r)) \cos(i_2 \theta)$$

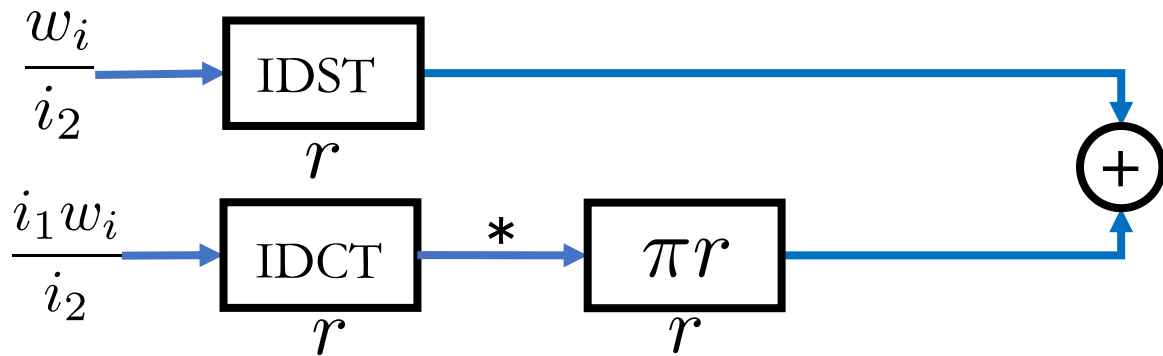

Fast Transformations

$$\begin{cases} \Phi_r^0(r, \theta) &= \sin(i_1 \pi r) \sin(i_2 \theta) \\ \Phi_\theta^0(r, \theta) &= \frac{1}{i_2} (\sin(i_1 \pi r) + i_1 \pi r \cos(i_1 \pi r)) \cos(i_2 \theta) \end{cases}$$

$$\mathbf{u}_\theta = \sum_{i=1}^r \frac{w_i}{i_2} (\sin(i_1 \pi r) + i_1 \pi r \cos(i_1 \pi r)) \cos(i_2 \theta)$$

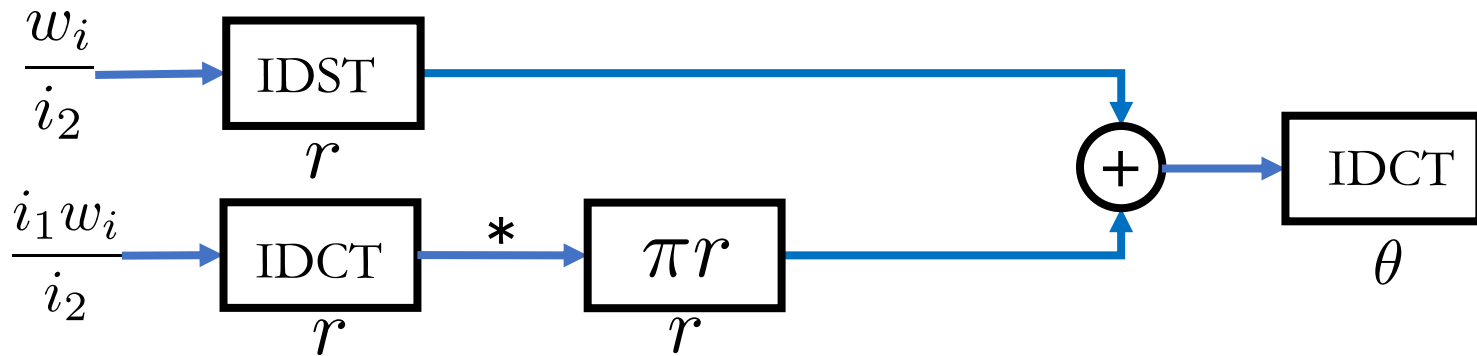

Eigenfluids in Spherical Coordinates

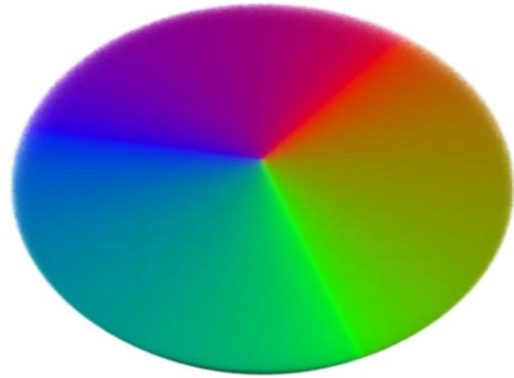
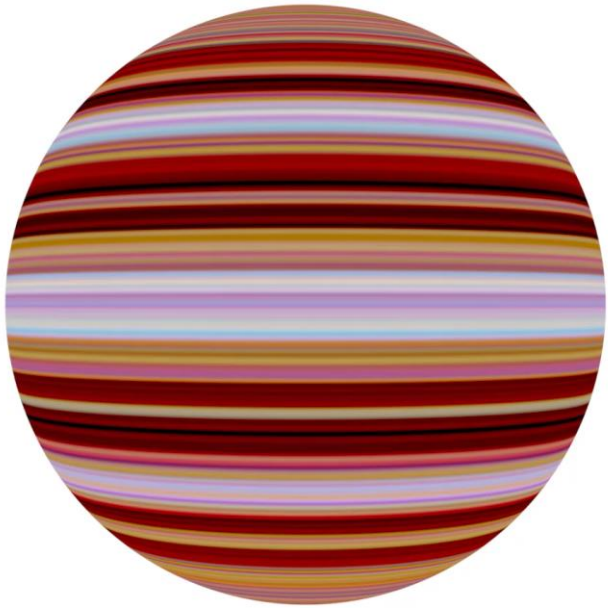

Eigenfluids in Spherical Coordinates

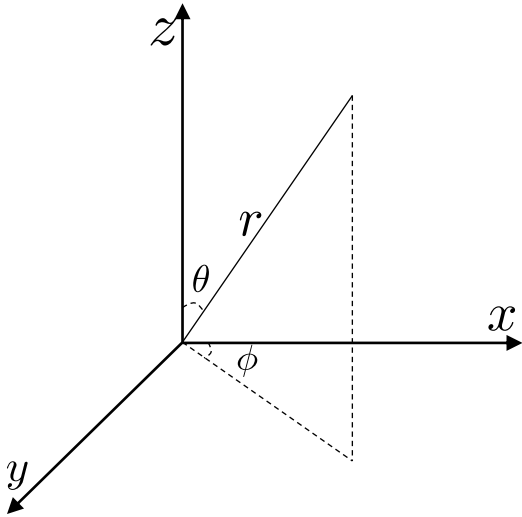

$$x = r \sin(\theta) \cos(\phi)$$

$$y = r \sin(\theta) \sin(\phi)$$

$$z = r \cos(\theta)$$

Eigenfluids in Spherical Coordinates

$$\nabla \cdot \mathbf{u} = \frac{1}{\cancel{r^2}} \frac{\partial(\cancel{r^2} \mathbf{u}_r)}{\partial r} + \frac{1}{r \sin(\theta)} \frac{\partial}{\partial \theta} (\mathbf{u}_\theta \sin(\theta)) + \frac{1}{r \sin(\theta)} \frac{\partial \mathbf{u}_\phi}{\partial \phi}$$



Codimensional spherical coordinates

$$\mathbf{u}_r = 0$$

Basis Functions

$$\begin{cases} \Phi_{\theta}^0 &= \sin(i_1\theta) \cos(i_2\phi), \quad i_1 > 0, \quad i_2 > 0, \\ \Phi_{\phi}^0 &= -\frac{1}{i_2} (\cos(\theta) \sin(i_1\theta) + i_1 \sin(\theta) \cos(i_1\theta)) \sin(i_2\phi) \end{cases}$$

$$\begin{cases} \Phi_{\theta}^1 &= \sin(i_1\theta) \sin(i_2\phi), \quad i_1 > 0, \quad i_2 > 0, \\ \Phi_{\phi}^1 &= \frac{1}{i_2} (\cos(\theta) \sin(i_1\theta) + i_1 \sin(\theta) \cos(i_1\theta)) \cos(i_2\phi) \end{cases}$$

Boundary Condition at the Pole

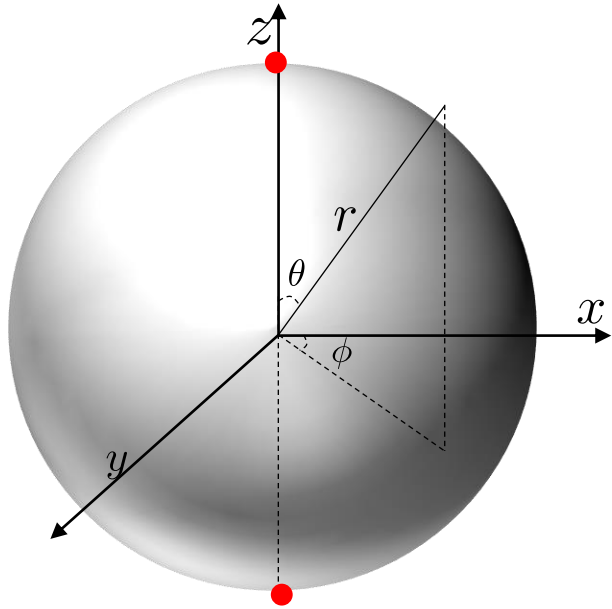

Poles:

$$\theta = 0, \theta = \pi$$

Enrichment Basis Functions

$$\begin{cases} \Phi_{\theta}^2 & = \cos(i_1 \theta) \cos(\phi) \\ \Phi_{\phi}^2 & = (-\cos(\theta) \cos(i_1 \theta) + i_1 \sin(\theta) \sin(i_1 \theta)) \sin(\phi) \end{cases}$$

$$\begin{cases} \Phi_{\theta}^3 & = \cos(i_1 \theta) \sin(\phi) \\ \Phi_{\phi}^3 & = (\cos(\theta) \cos(i_1 \theta) - i_1 \sin(\theta) \sin(i_1 \theta)) \cos(\phi) \end{cases}$$

Principal basis functions

Radial Coordinates

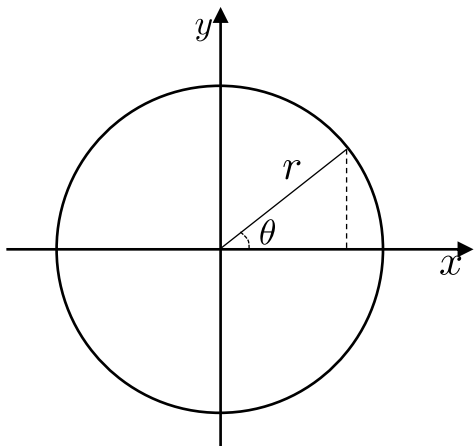

Polar

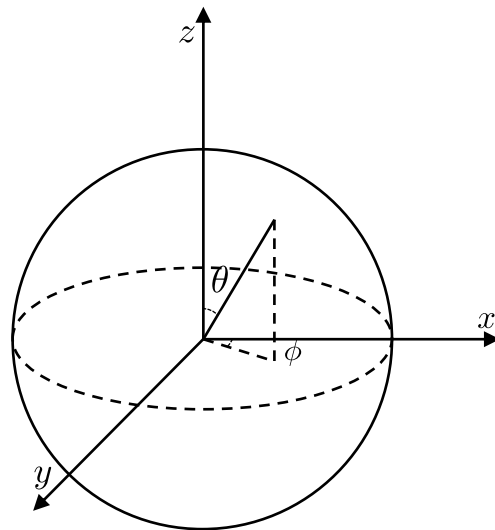

Spherical

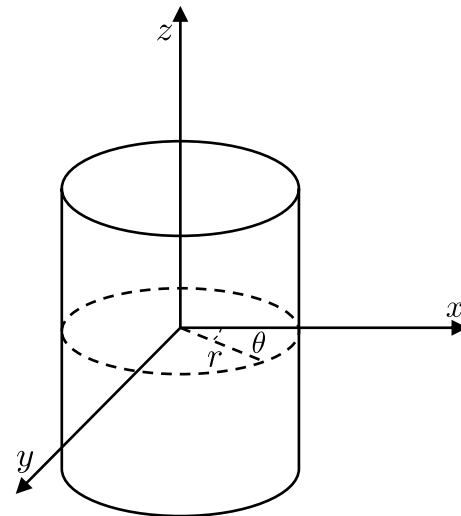

Cylindrical

Radial Coordinates

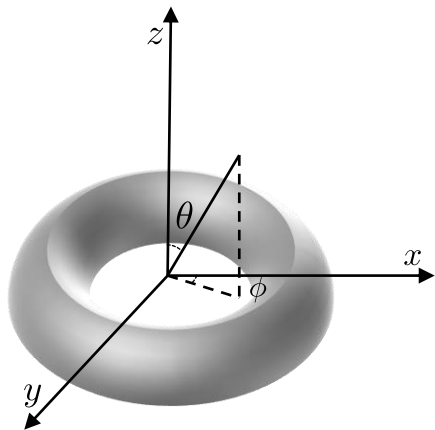

Toroidal

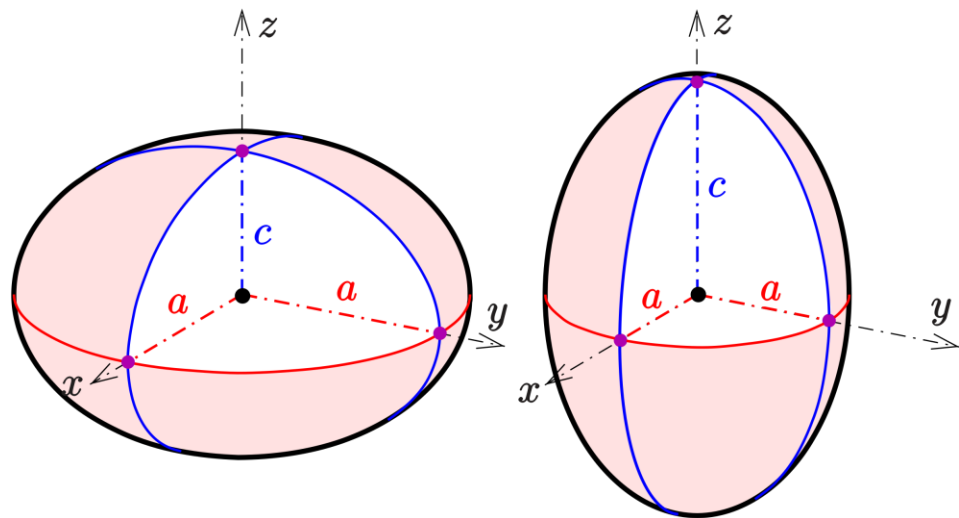

Spheroidal

Outline

- Previous work
- Scalable Laplacian Eigenfluids
- Our methods
- **Results**
- Contributions and future work

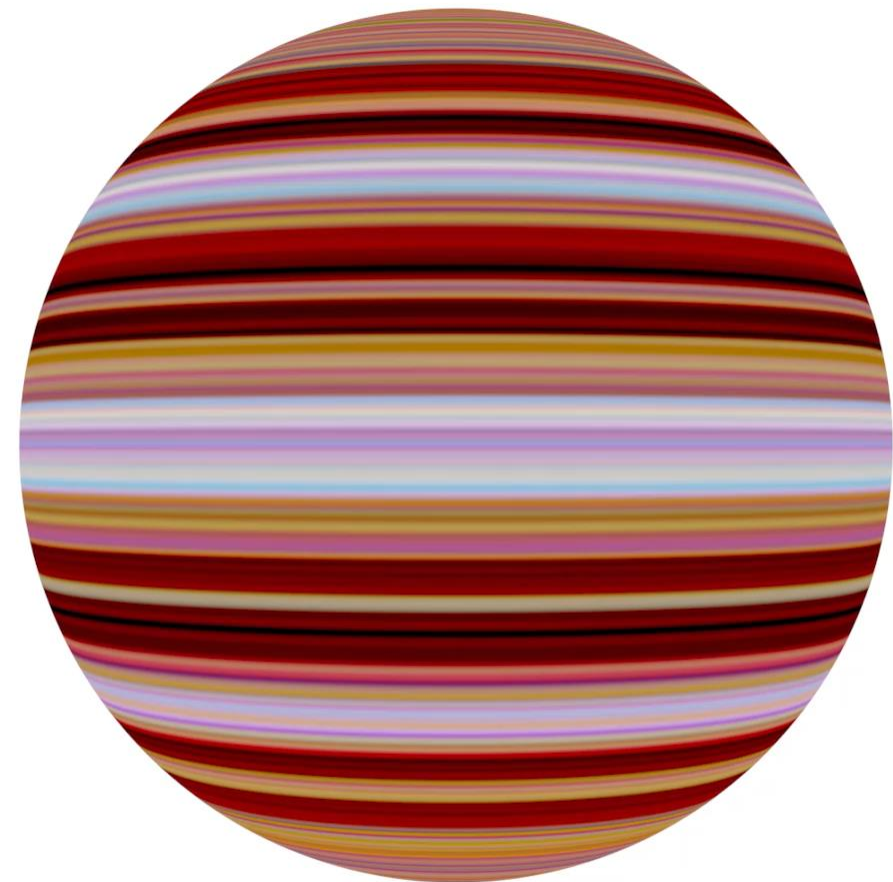

Without Coriolis forces

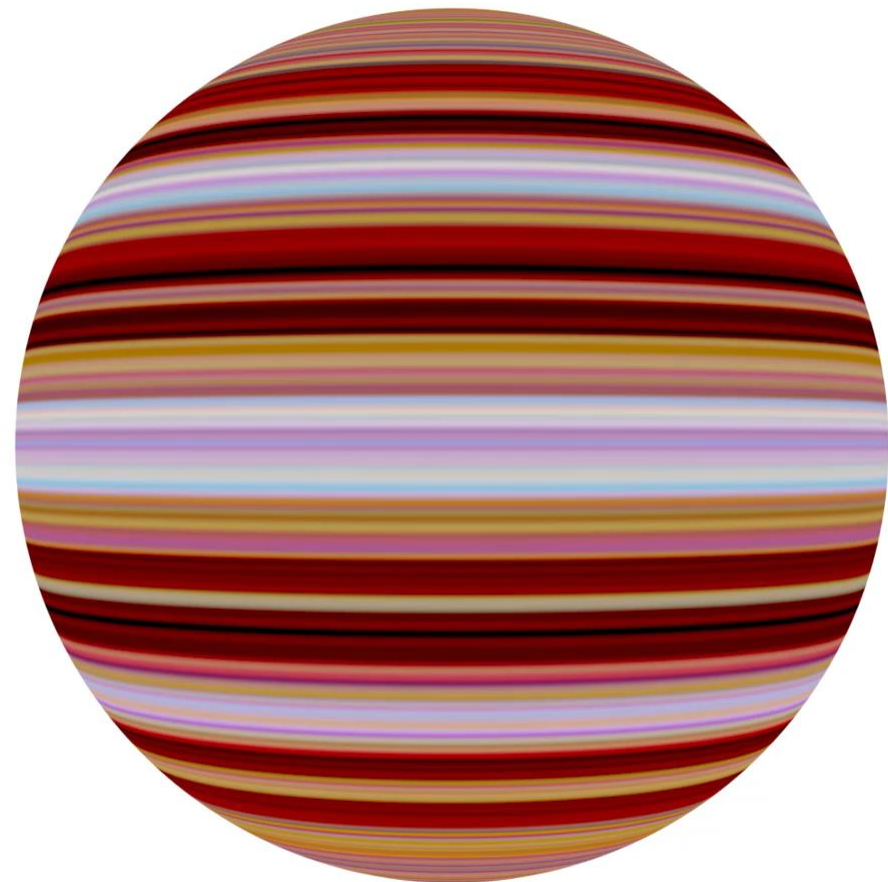

With Coriolis forces

Planetary flow
8K basis functions

3.9 seconds per frame

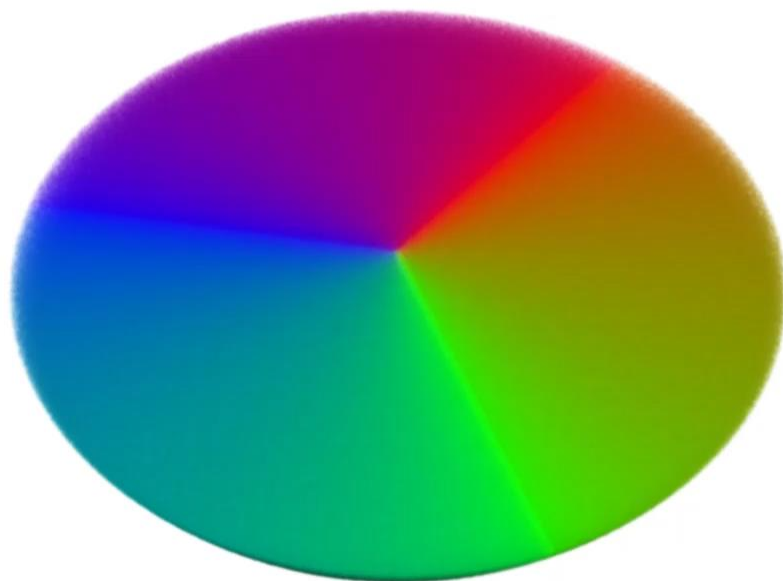

10.8 seconds
per frame
Sphere
6K basis functions

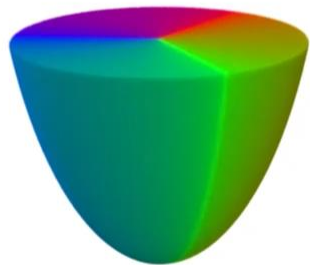

($b=0.4$)

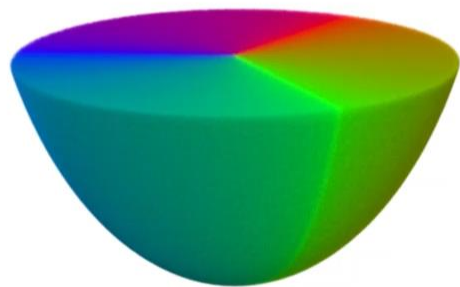

($b=0.6$)

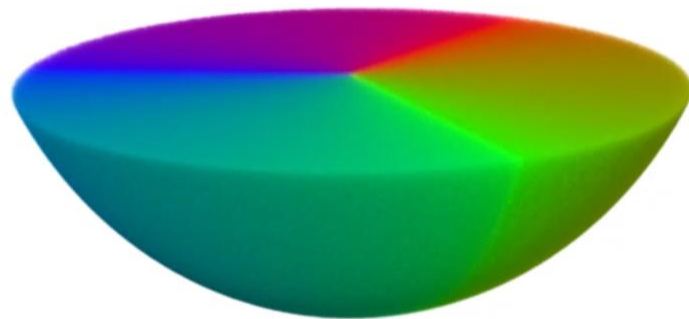

($b=0.9$)

Prolate spheroid, 6K basis functions 10 seconds per frame

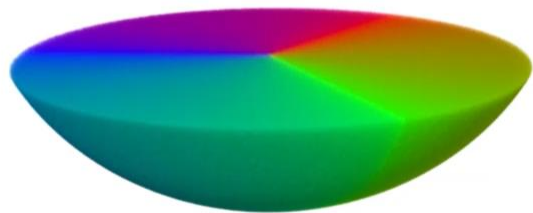

($b=0.9$)

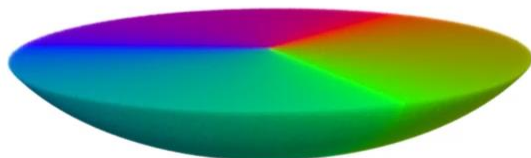

($b=0.6$)

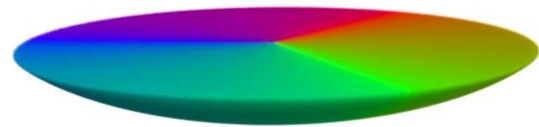

($b=0.4$)

Oblate spheroid, 6K basis functions 12 seconds per frame

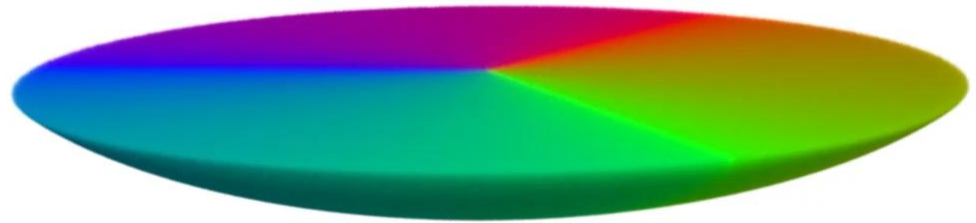
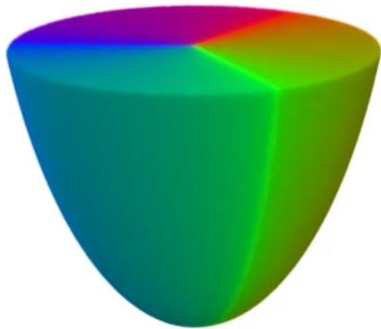

Spheroids ($b=0.4$), 6K basis functions



6.7 seconds
per frame
Tokamak Flow
6K basis functions

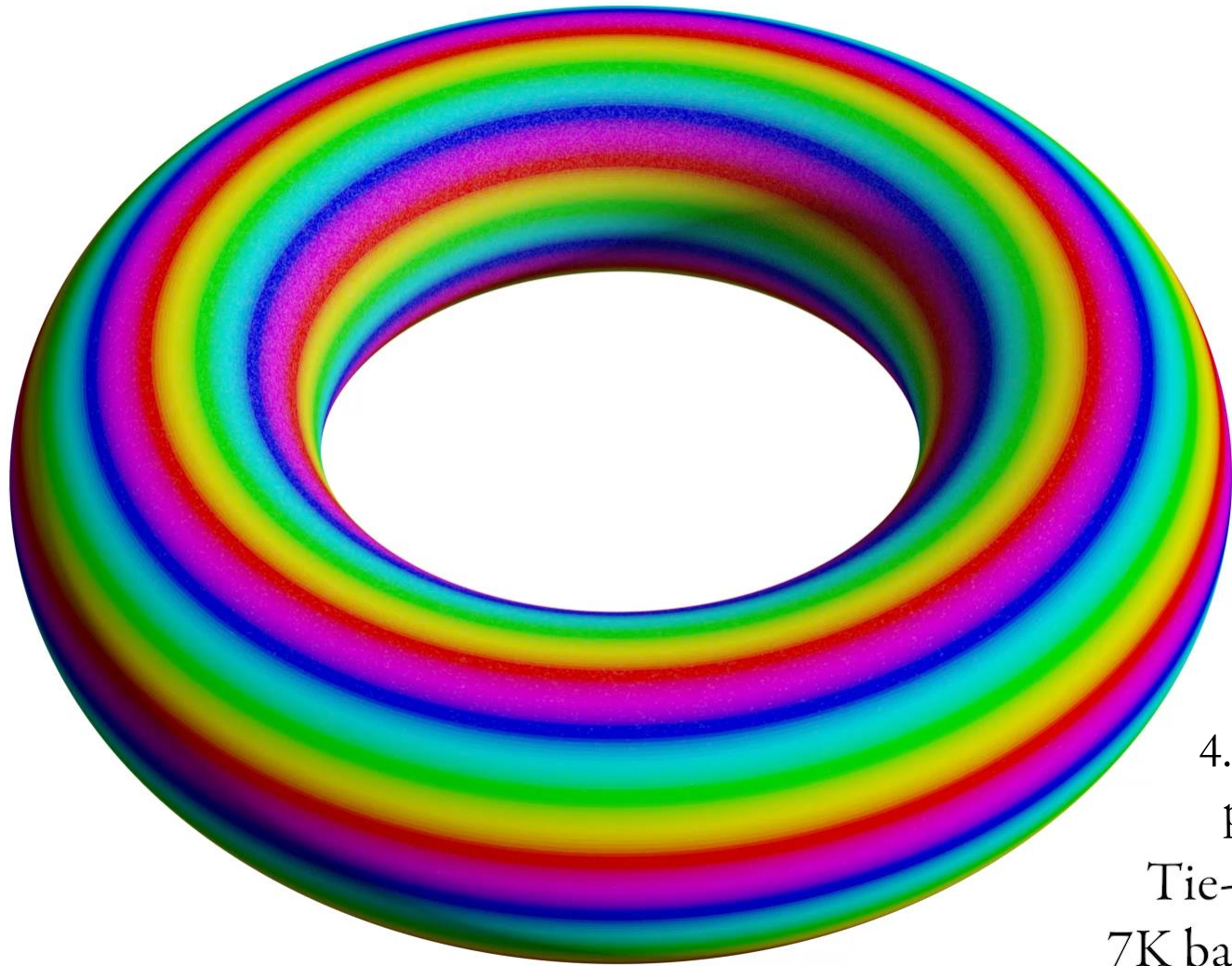

4.2 seconds
per frame
Tie-Dye Torus
7K basis functions

Cylinder tornado

12 seconds
per frame

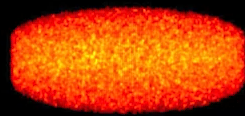

3K basis
functions

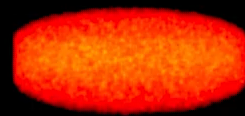

6K basis
functions

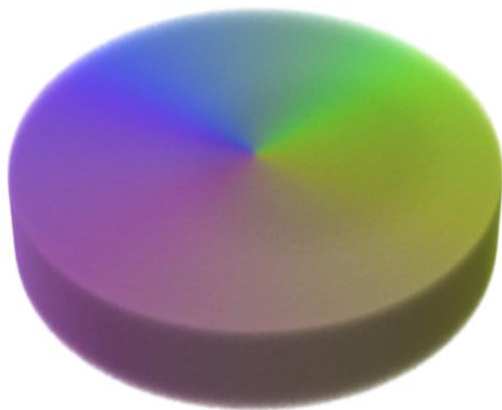

12.9 seconds per frame

Dropping balls

11K basis functions

visc: 0.003

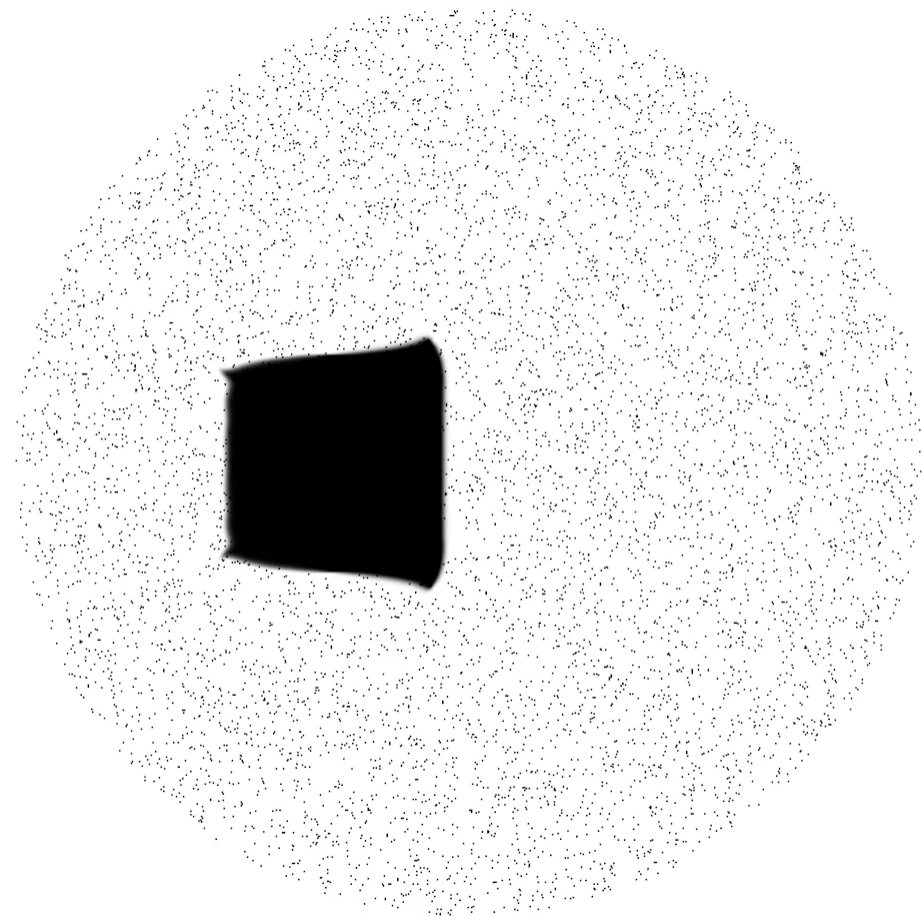

Dirichlet

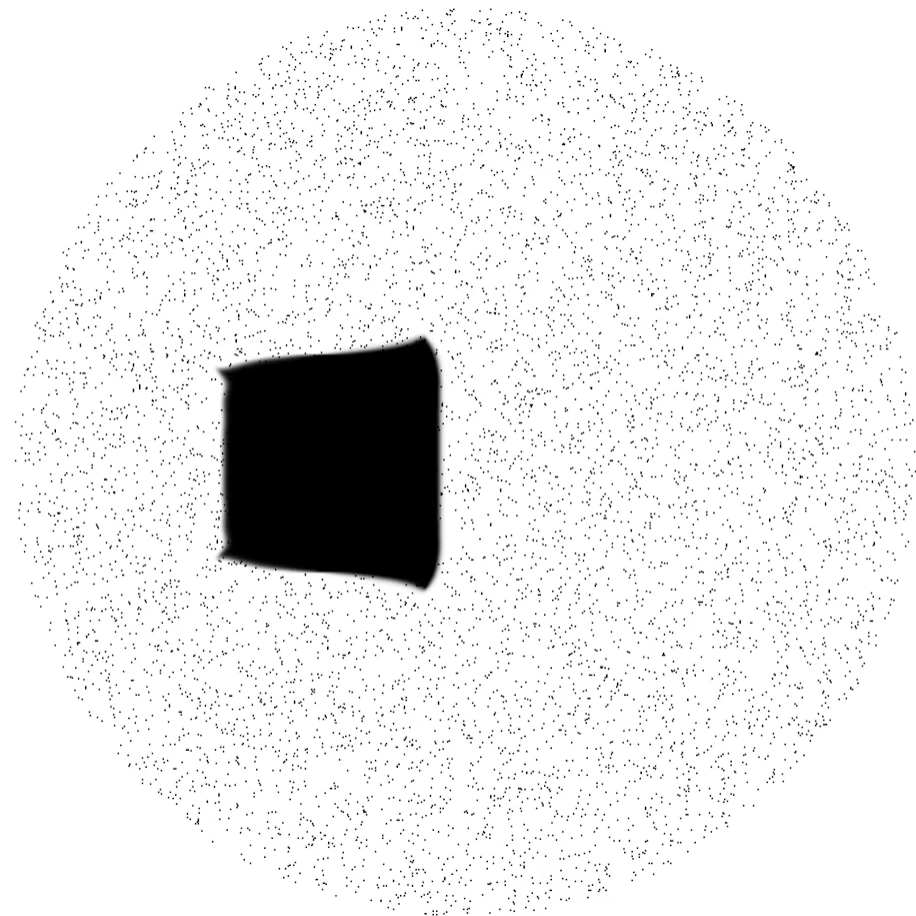

Neumann

Completeness Validation

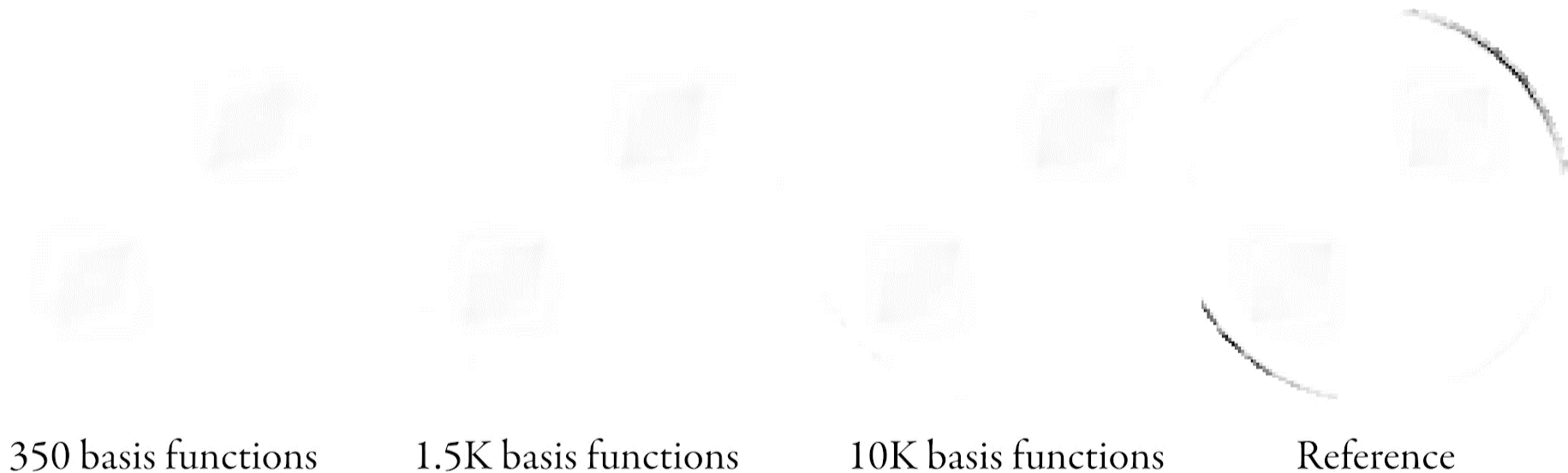

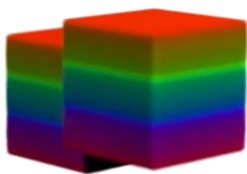

Dedalus

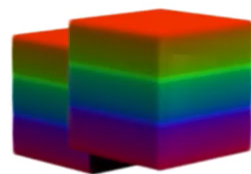

Ours

Outline

- Previous work
- Scalable Laplacian Eigenfluids
- Our methods
- Results
- Contributions and future work

Contributions

- A method for generating divergence-free basis functions
 - Support FFT
 - Smooth and continuous
 - Analytic
- Efficacy over many geometries
 - Spheres and Spheroids
 - Cylinders
 - Tori

Future Work

- Fluid up-sampling
- Curvilinear coordinates

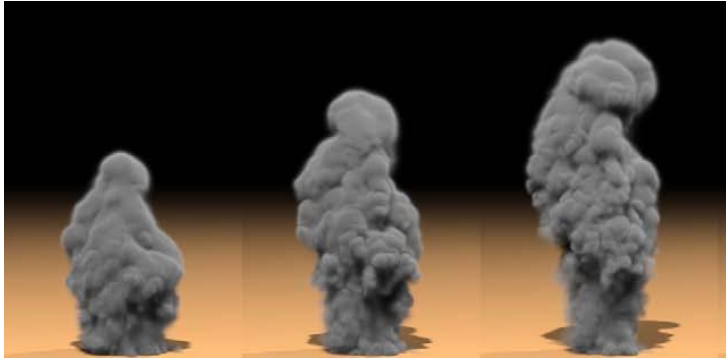

Vortex Particles: [Selle et al. 2005]

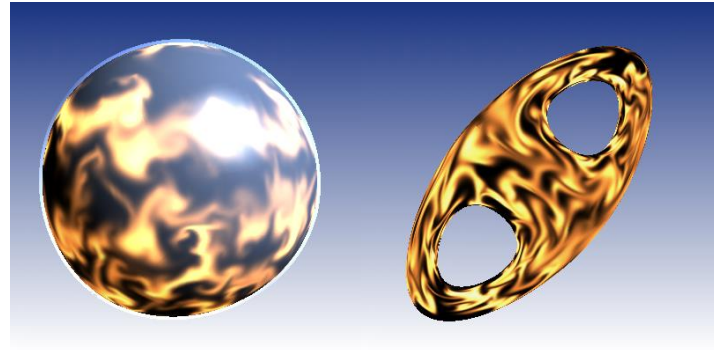

Curvilinear Coordinates: [Stam 2003]



SIGGRAPH ASIA 2021 TOKYO

CONFERENCE 14 - 17 DECEMBER 2021
EXHIBITION 15 - 17 DECEMBER 2021
TOKYO INTERNATIONAL FORUM, JAPAN

sa2021.siggraph.org



Thank you

Qiaodong Cui

Sponsored by



Organized by

